

Crystalline Silicon PV Module Installation Manual

1. Introduction

- 1.1 Purpose
- 1.2 Limitation of Liability
- 1.3 Precautions for Installation

2. Safety

- 2.1 General Safety
- 2.2 Installation Safety

3. Mechanical Installation

- 3.1 Installation Condition
- 3.2 Installation Methods

4. Electrical Installation

- 4.1 Installation Condition
- 4.2 Grounding

5. Maintenance

1. Introduction

1.1 Purpose

This document provides detailed instructions and valuable safety information regarding the installation, electrical connection, and maintenance of following Chint Solar Crystalline Photovoltaic modules:

CHSM60M(DG)/F-BH CHSM60M(DGT)/F-BH CHSM72M(DG)/F-BH CHSM72M(DGT)/F-BH

All the instructions should be read and understood before installation. The installers should be trained and conform to all safety precautions in this guide when installing the module. Keep this guide in a safe place for further reference.

1.2 Limitation of Liability

Because the use of this manual and the conditions or methods of installation, operation, use and maintenance of photovoltaic (PV) products are beyond Chint Solar's control, Chint Solar does not afford the responsibility and expressly disclaims liability for loss, damage, or expense arising out of or in any way connected with such installation, operation, use or maintenance. Chint Solar reserves the right to change the manual without prior notice.

1.3 Precautions of Installation

1.3.1 Module's unpack and transfer

- a) When the whole pallet of modules are delivered to the site and unloaded, make sure the safety of the modules especially if they need to be lifted for roof projects. Put them into a protective device and then lift it to the roof in case of bumping against the wall during the lifting process.
- b) Firstly, tear the stretch film, then move away the top cover after cutting off each module packing strip while unpacking. Two operators work as a group, grasp the module frame tightly in the same direction and take out the module one by one. It is a must that the operators remove the adhesive tape of the fixed module one by one, rive one piece and then take out one piece of module. We don't allow to tear off all the adhesive tape at one time to prevent the whole package from toppling over or falling down. The whole process must be taken very gently. Don't collide with any hard objects or let any parts of the frame touch and drag on the ground.
- c) After unpacking the modules should be installed that day as far as possible. It's recommended to take the right amount of modules according to the progress of the project

every day. Heavy rain and other inclement weather may have the potential to soak the packaging which can affect product reliability, such as storms, typhoons, hurricanes or other events in which they may be blown away. If the users need to store modules before installation, do not open the package, the goods should be stored in a room temperature, dark, dry and ventilated place.

1.3.2 Module's Stack

- a) When a module is taken out of the box, cardboard bedding below should be applied in order to avoid contact with cement surface / ground, hard metal or tile. Modules should be placed neatly and should not be dropped, slammed or scratched.
- b) When stacking modules, it needs to be stacked neatly in the horizontal plane, under the condition of the glass facing down and the back way piled up, while the cardboard bedding need to be underside the modules. If the modules will be installed on the rooftop, the number of each stack is suggested no more than 20. In case of the poor load-bearing capacity, it's recommended that the designer and/or installer check with the structural engineer or architect to determine the amount of load allowable for specific location. During the whole process, the installation tools and other objects must be prevented from contacting the module surface.
- c) If the modules are requested to be classified by current, the handling personnel are required to carry out of the level of the current and make a mark separately according to the power on the list. (e.g. 275W-L, identifies the modules of the packaging according to the power on the list, indicating a low current position; 275W-H, compared to high current position). Usually, the same series of modules in the same current position are required in accordance with the system design requirements.
- d) If the modules are color-coded and marked the corresponding logo on the carton due to the customer requirements, when modules are taken out and stacked, they should be labeled to avoid confusion. Usually the same row or the same square have the same color according to the system design requirements.
- e) Due to the complexity and difference of the construction site, these precautions may not cover all items, please refer to the specific construction standards.

2. Safety

2.1 General Safety

- 2.1.1 Consult and follow local codes and other applicable laws concerning required permitting as well as installation & inspection requirements, rules, and regulations.
- 2.1.2 PV modules should be installed and maintained by qualified personnel.
- 2.1.3 Use the same performance modules within a given series.
- 2.1.4 Follow all safety precautions of all components used in the system.
- 2.1.5 Do not shade portions of the PV module surface from the sun for a long period of time. The shaded cell may become hot (hot spot phenomenon), which can result in solder joints peeling off.
- 2.1.6 Do not clean the glass surface with chemicals.
- 2.1.7 Do not drop the PV module or drop objects onto the PV module.
- 2.1.8 Do not concentrate sunlight on the modules or panels.
- 2.1.9 Do not attempt to disassemble the modules, and do not remove any attached components from the modules.
- 2.1.10 Do not scratch or hit at the back sheet, the glass, the terminal box. Do not pull the cables or touch them with bare hands.
- 2.1.11 Do not drill holes in the frame or scratch the anodized film of the frame.
- 2.1.12 Keep the PV module packed in the carton until installation.
- 2.1.13 Do not use modules near equipment or in places where flammable gases may be generated.
- 2.1.14 Do not use modules in an environment with aliphatic, aromatic, phenols, ketones, halogenated substance or mineral oil, which may corrode the junction box by chemical attack.

2.2 Installation Safety

- 2.2.1 Wear protective clothing such as head gear, insulating gloves, safety shoes as prescribed by local safety codes. Use insulated tools when installing the modules.
- 2.2.2 Do not install the modules in heavy rain, snow, or otherwise wet or windy conditions.
- 2.2.3 Completely cover the PV module surface with an opaque material during PV module installation and wiring to prevent accidental charge buildup.
- 2.2.4 Plug in connectors tightly when working on wiring.
- 2.2.5 Due to the risk of electrical shock, do not perform any work if the terminals of PV module are wet.
- 2.2.6 Do not touch the terminal box and the end of output cables (connectors) with bare hands.
- 2.2.7 Do not unplug the connector under load.

- 2.2.8 Do not work alone.
- 2.2.9 Wear a safety harness if working far above the ground.
- 2.2.10 Do not wear metallic jewelry, which can cause electric shock, while installing or troubleshooting the PV system.
- 2.2.11 Follow the safety regulations for any and all other system components, including wires, connectors, charging regulators, batteries, inverters, etc.
- 2.2.12 Do not expose wires to direct sunlight. Use UV-resistant cable.
- 2.2.13 Do not damage the surrounding PV modules or mounting structure when replacing a PV module.
- 2.2.14 Do not change any PV module components (diode, junction box, connectors, etc.).
- 2.2.15 The maximum reverse current is 27A for bifacial module. Application of the blocking diode and fuse in the combiner box are recommended for reverse current protection when more than two strings are connected in parallel.
- 2.2.16 A certain gap is maintained between the PV module and the mounting surface to prevent the mounting surface touching the junction box.
- 2.2.17 Standing on the solar PV module is forbidden and also prohibit installation tools or other objects hitting surface of the solar PV module.
- 2.2.18 The solar modules are recommended to be installed over a fireproof and insulating roof covering when installed on a roof.
- 2.2.19 PV cable connection cannot be too tight, it is recommended that the connector and the backsheet have a certain gap.
- 2.2.20 In sandy regions, in order to avoid getting sand into the connector, we suggest to short circuit module connectors before installation. If grains of sand get into the connectors it, may cause internal live parts wear and tear and affect electrical safety.

3 Mechanical Installation

3.1 Installation Conditions

- 3.1.1 Extreme environment temperature: -40°C to $+85^{\circ}\text{C}$
- 3.1.2 Operating temperature: -40°C to $+85^{\circ}\text{C}$
- 3.1.3 Please refer to the detailed mounting instructions as Chapter 3.2.
- 3.1.4 Tilt Angle selection: The installation should be facing north in the southern hemisphere and facing south in the northern hemisphere.
- 3.1.5 To maintain the modules' Class A fire rating, the fire class of the roof and building materials should be higher than Class A.
- 3.1.6 To maintain the modules' fire performance type 3(for US market), it could be possible to achieve the Class A system fire rating, with the Class A class racking system.

3.2 Installation Methods

3.2.1 Bolting through the mounting holes

- ① All modules must be secured by at least 4 bolts (as shown in figure 1 and 2). For maximum safety precaution, it is recommended to make use of all installation holes available, as shown in figure 3.
- ② While installing, the module frame should be parallel to the mounting rack to avoid casting shadow on the rear side, as shown in figure 4.

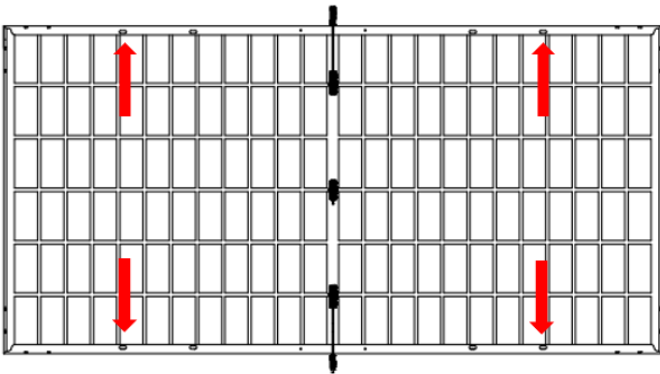

Figure 1

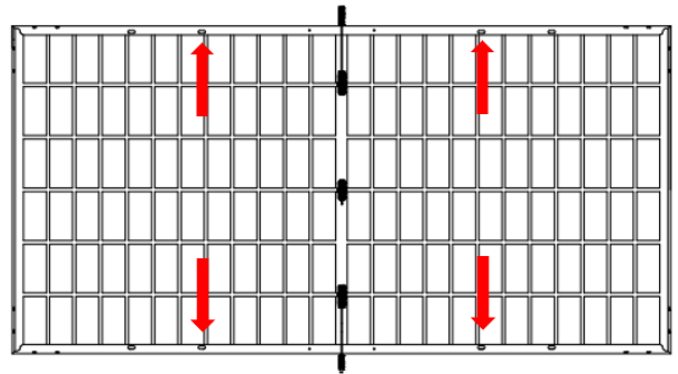

Figure 2

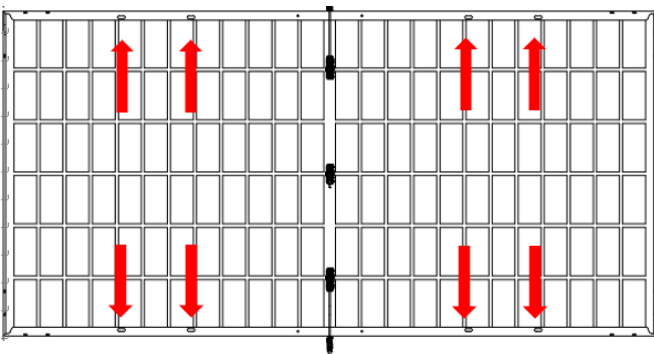

Figure 3

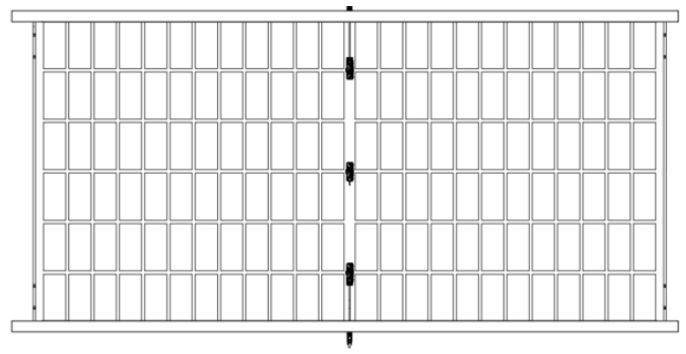

Figure 4

Note: the red arrows above is indicative of the bolts' location. The installation steps are as follows (figure 5):

1. Place the module underneath the mounting rack.
2. Insert 4 stainless bolts (M8) into the mounting holes in figure 1 or 2.
3. Make sure that each bolt is installed with two washers, one on each side of the rack. then screw them tight onto spring washer or toothed washer, and at last, lock them with stainless nuts.
4. The reference value of tightening torques should be within 17~23 Nm for M8 bolts. For the torque value, recommendations from specific clamping hardware suppliers should prevail.

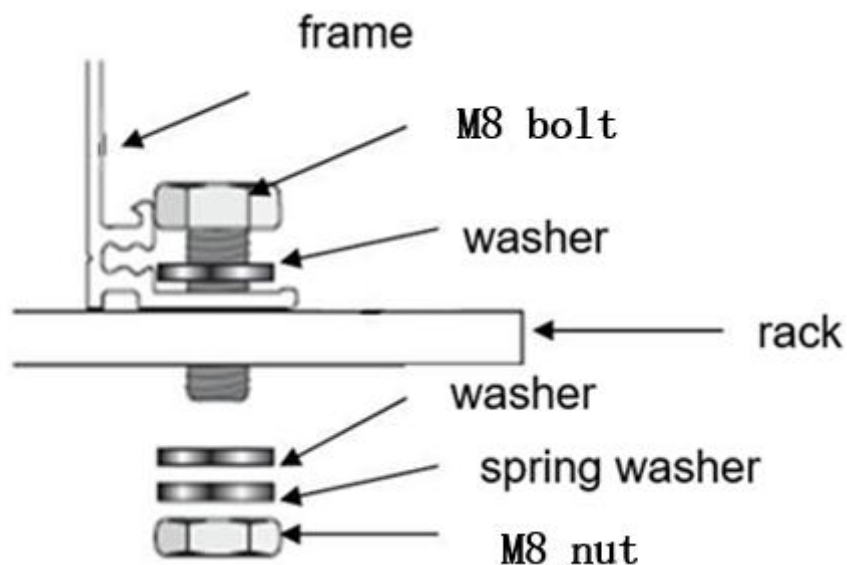

Figure 5

3.2.2 Clamping on the frame surface

3.2.2.1 Double glass module

During the installation of bifacial modules, the frame and mounting rack should maintain parallel, as shown in figure 6.

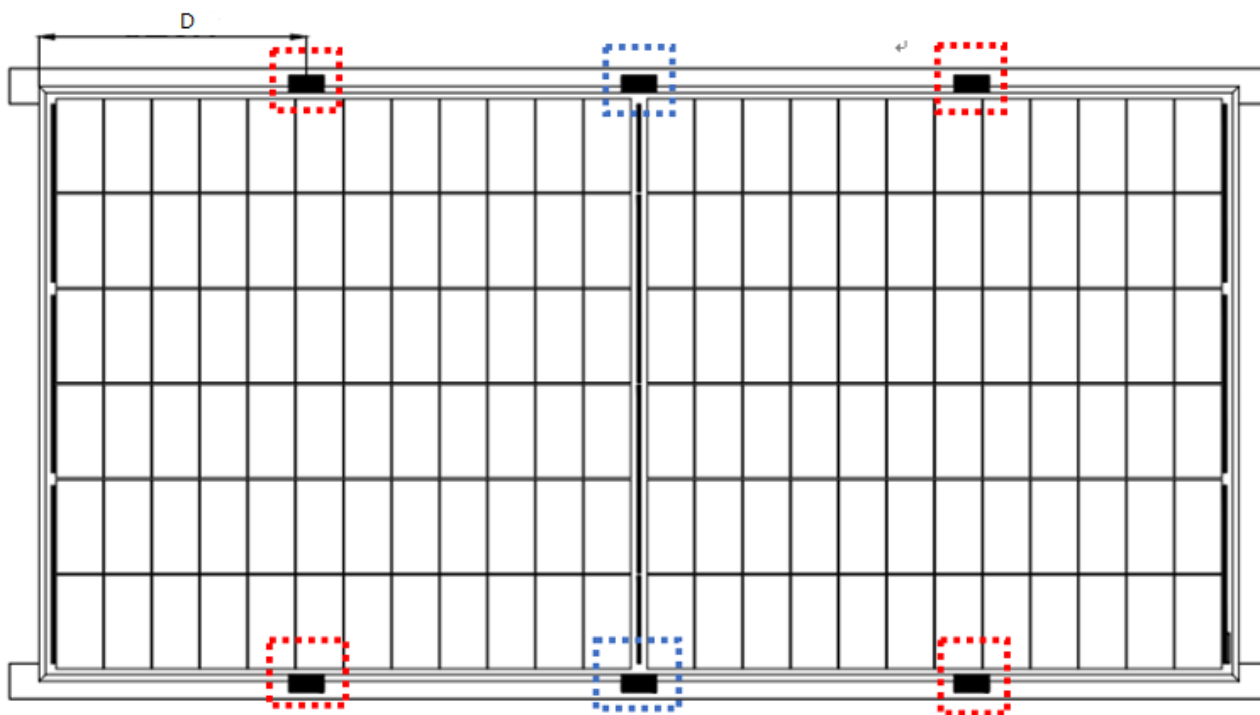

Figure 6

Remark:

- 1) The length of supporting bars must be longer than the length of module frame, otherwise please confirm with our product team to get approval.
- 2) As for above figure 6, the solid red rectangles indicate primary clamp installation positions and the center positions of long frames where clamps can be added for additional support.
- 3) The above figures illustrate the proper installation method of frame surface clamp. “D” indicates its mounting location, as specified as follows:
- 4) The max tested snow/wind load as Table1, (e.g. +5400, identifies the max tested snow/wind load on the front of the module; -2400, identifies the max tested wind load on the back of the module).

Module type	Installation		Figure 1	Figure 2	Figure 3	Figure 6 D=1/4L±50 (mm)
	Dimensions	L*W*H (mm)				
CHSM60M(DG)/F-BH		1791*1052*30	+5400 -2400	+2400 -2400	+5400 -2400	+5400 -2400
CHSM60M(DGT)/F-BH		1791*1052*30	+5400 -2400	+2400 -2400	+5400 -2400	+5400 -2400
CHSM72M(DG)/F-BH		2131*1052*30	+5400 -2400	+2400 -2400	+5400 -2400	+5400 -2400
CHSM72M(DGT)/F-BH		2131*1052*30	+5400 -2400	+2400 -2400	+5400 -2400	+5400 -2400

Table 1

- 5) Each aluminum clamp is equipped with a M8 bolt, a plain washer, a spring washer and a M8 nut, to fasten the module:
 - a) Place the module on the two supporting bars (not provided). The bars should be made with stainless material and treated with an anti-corrosion process (e.g., anodic oxidation treatment) or aluminum profile. Each solar PV module needs at least four clamps to fix. Do not make the clamp contact the glass directly or make the aluminum frame deformation in the installation process, and avoid the shadow of solar PV components.
 - b) The bar's top surface contacted with module frame should come with grooves compatible with an M8 bolt.
 - c) If the bars do not come with grooves, holes of a suitable diameter may need to be drilled to allow bolts to be attached to the bars at the same locations as mentioned above.
 - d) Secure each clamp by attaching plain washer, spring washer, and nut, in that order.
 - e) Both of close-ups of Figure 8, indicating the middle clamps and Figure 9, indicating the side clamps for reference. Suggest the dimensions for middle clamps are: $a \geq 40$ mm, $b \geq 26$ mm, $c = 8$ mm, $d \geq 28$ mm, and $\varnothing = 9$ mm. The torque for tightening the nut and bolts are recommended 17~23Nm when the property class of bolts and screws is Class 8.8.

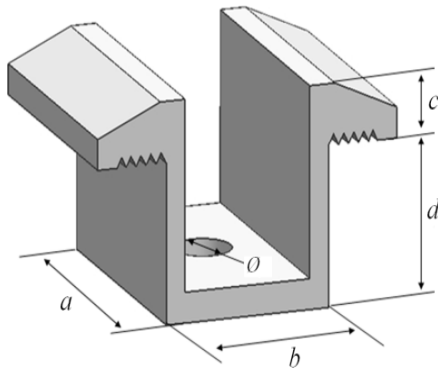

Figure 8

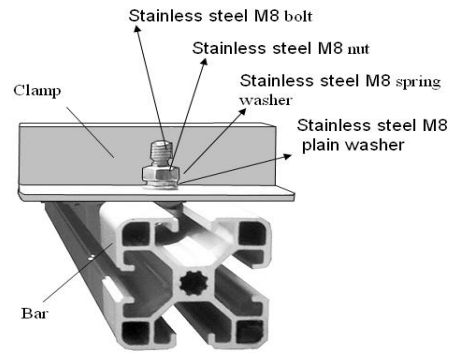

Figure 9

- f) For figure 6 mounting method, the modules must be supported along the length of the edge, and should overlap the array rail by 10mm – 14mm, as shown in figure 10.

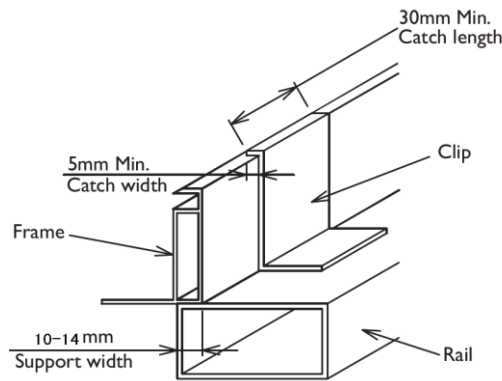

Figure 10

4 Electrical Installation

4.1 Installation Condition

- 4.1.1 The electrical characteristics are within $\pm 10\%$ of the indicated values of I_{sc} , V_{oc} and P_{mpp} under the standard test conditions (irradiance of 1000 W/m^2 , AM1.5 spectrum, cell temperature of 25°C).
- 4.1.2 The IEC & UL standard maximum system voltage for the bifacial module series is 1500V.
- 4.1.3 Connect quantity of modules that match the voltage specifications of the inverters used in system. Modules must not be connected together to create a voltage higher than the permitted maximum system voltage under the lowest local temperature conditions.
- 4.1.4 Under normal conditions, a photovoltaic module is likely to experience conditions that produce more current and/or voltage than reported at standard test conditions. Accordingly, the value of I_{sc} marked on this module should be multiplied by a factor of 1.25 when determining component conductor ampacities, fuse sizes, and size of controls connected to the PV output.

- 4.1.5 Refer to Section 690-8 of the National Electrical Code for an additional multiplying factor of 125% (80% derating) which may be applicable.
- 4.1.6 Each module (or series-connected string of modules) shall be provided with the maximum series fuse, specified 20A for bifacial module.
- 4.1.7 Use a special solar cable and plugs for installing the PV system and make sure that all connections are safe and tight. The cable should be 4 mm² (12AWG), and able to withstand the maximum possible system open-circuit voltage.
- 4.1.8 Bypass diodes are included in module junction boxes to avoid decreased module performance in the event of shade. Please check the relevant product datasheet for the specific diodes of J-box.
- 4.1.9 Prohibit interconnection between different types of connectors.

4.2 Grounding

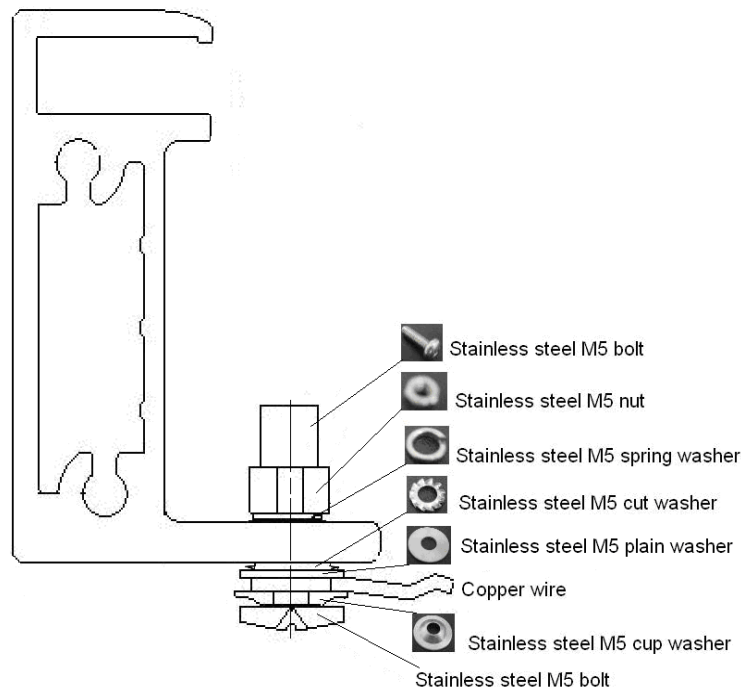

(n) Grounding the aluminum frame with copper wire

- 4.2.1 The grounding requirements must be checked in accordance with the applicable regulations and standards before work is started.
- 4.2.2 Use the marked 5.5 mm grounding holes to ground the anodized frame. Use one M5 nut, two M5 cut washers, one M5 plain washer, one M5 spring washer, and one M5 bolt and the copper wire. All nuts, bolts, and washers are type M5 and should be made of stainless steel (Fig. (n)).
- 4.2.3 Put the bolt through the cup washer and wrap the copper wire around the bolt. (Note that the copper wire cannot be attached directly to the aluminum.)
- 4.2.4 Put the bolt through the cut washer and then through the hole in the aluminum frame.
- 4.2.5 Add the spring washer and nut on the other side of the bolt and tighten to secure all parts.

The tightening torque should be 210 ± 20 N•cm.

- 4.2.6 Approve the use of UL-467 certified bonding and grounding devices, including Burndy (formerly Wiley Electronics) Washer Electrical Equipment Bonding (WEEB) and similar devices, such as barbed washers, that meet the requirements of UL-467 as suitable for electrical bonding and grounding PV modules to PV mounting systems.
- 4.2.7 Other grounding methods may be allowable when tested with the racking system per UL 2703 requirements.

5 Maintenance

- 5.1 Regularly carry out a visual inspection for dirt, dust, bird dropping, leaves, and other detritus covering the modules.
- 5.2 If snow is present, a soft-bristled brush with soft bristles may be used to clean the surface of the modules.
- 5.3 Regular electrical and mechanical inspection by a licensed professional will keep the system safe and operating at maximum efficiency.
- 5.4 Recommended PV module Clean-up period

To get high output performance, PV module needs to be cleaned-up periodically as below:

- ① Normal: Minimum one time per every month; Dust weather: Right away after the dust wind;
- ② The period of the PV module cleaning shall be determined by the condition of the weather & pollution. O&M operator shall keep a record of weather condition everyday with data.

5.5 Condition of Cleaning

- 5.5.1 Use clean water or filtered water with soft type material (a sponge) to wipe the PV module. Never use chemicals on the surface of the module.
- 5.5.2 Cleaning after sunset or before sunrise is recommended for safety of O&M operator shock from heat stroke.
- 5.5.3 Do not use abrasive powder, abrasive cleaners, scrubber cleaners, polishers, sodium hydroxide, benzene, nitro-thinners, acid or alkali and other chemical substances.
- 5.5.4 Do not clean broken glass or modules with broken lines or exposed wires, as it may cause the electric shock.



浙江正泰太阳能科技有限公司
CHINT SOLAR (ZHEJIANG) CO., LTD

CHINT SOLAR (ZHEJIANG) Co., Ltd.

Add: 1335 Bin'an Rd, Binjiang District, Hangzhou, China 310053

Tel: 86-571-5603 1888

Fax: 86-571-5603 2333

<http://energy.chint.com/>